

Electric powered forklift 2.0 - 3.5 ton

TRAIIGO⁸⁰



Electric powered forklift 2.0 - 2.5 ton

Truck specifications				9FBMK20T	9FBMK25T	9FBM25T	9FBH25T	
Identification	1.1	Manufacturer		Toyota	Toyota	Toyota	Toyota	
	1.2	Model		9FBMK20T	9FBMK25T	9FBM25T	9FBH25T	
	1.3	Drive		Electric	Electric	Electric	Electric	
	1.4	Operator type		driver seated	driver seated	driver seated	driver seated	
	1.5	Load capacity/rated load	Q	kg	2000	2500	2500	2500
	1.6	Load centre	c	mm	500	500	500	600
	1.8	Load distance, centre of drive axle to fork	x	mm	420	420	420	440
	1.9	Wheelbase	y	mm	1575	1575	1735	1735
Weight	2.1	Service weight		kg	4318	4736	5087	5302
	2.2	Axle load, with load, front/rear		kg	5295 / 1024	6235 / 1001	6298 / 1290	6706 / 1096
	2.3	Axle load, without load, front/rear		kg	2126 / 2192	2274 / 2462	2472 / 2615	2717 / 2585
Tyres	3.1	Tyres: C=Cushion, SE=Super elastic, PN=Pneumatic, TW=Twin			SE	SE	SE	SE
	3.2	Tyre size, front (SE)			23x9-10	23x9-10	23x9-10	23x10-12
	3.3	Tyre size, rear (SE)			18x7-8	18x7-8	18x7-8	18x7-8
	3.5	Wheels, number front/rear (x = driven wheels)			2x/2	2x/2	2x/2	2x/2
	3.6	Track width, front	b ₁₀	mm	986	986	986	946
	3.7	Track width, rear	b ₁₁	mm	940	940	940	940
	Dimensions	4.1	Tilt of mast/fork carriage forward/backward	α/β	deg	4,25/8	4,25/8	4,25/8
4.2		Height, mast lowered	h ₁	mm	2235	2235	2235	2355
4.3		Free lift	h ₂	mm	120	120	120	125
4.4		Lift	h ₃	mm	3300	3300	3300	3300
		Lift height	h ₂₃	mm	3345	3345	3345	3345
4.5		Height, mast extended	h ₄	mm	3979	3979	3979	3950
4.7		Height of overhead guard	h ₆	mm	2215	2215	2215	2215
4.8		Seat height/stand height	h ₇	mm	1230	1230	1230	1230
4.12		Coupling height	h ₁₀	mm	460	460	460	460
4.19		Overall length	l ₁	mm	3280	3280	3440	3653
4.20		Length to face of forks	l ₂	mm	2280	2280	2440	2453
4.21		Overall width	b ₁	mm	1195	1195	1195	1195
4.22		Fork dimensions	s/e/l	mm	40/100/1000	40/100/1000	40/100/1000	45/100/1200
4.23		Fork carriage DIN 15 173, class/type A, B			IIA	IIA	IIA	IIA
4.24		Fork-carriage width	b ₃	mm	1070	1070	1070	1070
4.31		Ground clearance, with load, below mast	m ₁	mm	95	95	95	95
4.32		Ground clearance, centre of wheelbase	m ₂	mm	132	132	132	132
4.33		Aisle width for pallets 1000x1200 crossways	A _{st}	mm	3646	3646	3796	3809
4.34	Aisle width for pallets 800x1200 lengthways	A _{st}	mm	3845	3845	3995	4008	
4.35	Turning radius	W _a	mm	2025	2025	2175	2175	
4.36	Internal turning radius	b ₁₃	mm	529	529	545	545	
Performance data	5.1	Travel speed, with/without load, Standard Performance		km/h	16/16 19/20	16/16 19/20	16/16 19/20	16/16 19/20
	5.2	Lift speed, with/without load, Standard Performance		m/s	0,43/0,60 0,46/0,63	0,38/0,60 0,46/0,63	0,38/0,60 0,46/0,63	N.A. 0,40/0,55
	5.3	Lowering speed, with/without load		m/s	0,56/0,45	0,56/0,45	0,56/0,45	0,56/0,45
	5.5	Drawbar pull, with/without load, Standard Performance		N	8000 10000	8000 10000	8000 10000	8000 10000
	5.6	Max. drawbar pull, with/without load, Standard Performance		N	18000 20000	18000 20000	18000 20000	18000 20000
	5.7	Gradeability, with/without load, Standard Performance		%	16/26 23/29	14/24 20/29	13/21 19/29	13/20 18/29
	5.8	Max. gradeability, with/without load, Standard Performance		%	26/29 31/29	20/29 25/29	20/29 25/29	20/29 25/29
	5.9	Acceleration time, with/without load, Standard Performance		s	4,8/4,5 4,4/4,2	5,0/4,7 4,5/4,2	5,0/4,7 4,6/4,2	5,0/4,7 4,6/4,2
	5.10	Service brake			mech./hydr.	mech./hydr.	mech./hydr.	mech./hydr.
	Electric motor	6.1	Drive motor rating S2 60 min, Standard Performance		kW	16,1 21,4	16,1 21,4	16,1 21,4
6.2		Lift motor rating S3 15%, Standard Performance		kW	17,3 16,7	17,3 16,7	17,3 16,7	N.A 16,7
6.3		Battery acc. to DIN 43 531/35/36 A, B, C, no			DIN 43536 A	DIN 43536 A	DIN 43536 A	DIN 43536 A
6.4		Battery voltage, nominal capacity K _s		V/Ah	80/500	80/560	80/700	80/700
6.5		Battery weight		kg	1210	1558	1863	1863
6.6		Energy consumption acc. to EN16796:2016, Standard Performance		kWh/h	5,8 5,4	6,3 5,8	6,4 5,9	N.A 6,3
Other	8.1	Type of drive control			AC	AC	AC	AC
	8.2	Operating pressure for attachments		bar	160	160	160	160
	8.3	Oil volume for attachments		l/min	40	40	40	40
	8.4	Sound level at the driver's ear according to EN 12 053		dB(A)	64,9	64,9	64,9	64,9

All data are based on table configuration. Other configurations may give other values. Products and specifications are subject to change without notice.

Mast dimensions and rated capacities

Model			V					FV				FW				FSV					FSW						
9FBM(K)20,25T	Lift height	h_{23}	3040	3340	3740	4040	4540	3040	3340	3740	4040	3040	3340	3740	4040	4340	4740	5040	5540	6040	6540	4390	4740	5040	5540	6040	6540
	Lift	h_3	3000	3300	3700	4000	4500	3000	3300	3700	4000	3000	3300	3700	4000	4300	4700	5000	5500	6000	6500	4350	4700	5000	5500	6000	6500
	Height, mast lowered	h_1	2135	2235	2585	2835	3085	2135	2235	2585	2835	2105	2235	2505	2655	2135	2235	2395	2585	2835	3085	2105	2205	2305	2505	2655	2855
	Height, mast extended ¹⁾	h_4	3679	3979	4395	4795	5295	3674	3974	4374	4674	3605	3905	4305	4605	4974	5374	5674	6174	6674	7174	4955	5305	5605	6105	6605	7105
	Height, mast extended ²⁾	h_4	4220	4520	4920	5220	5720	4289	4589	4989	5289	4220	4520	4920	5220	5589	5989	6289	6789	7289	7789	5570	5920	6220	6720	7220	7720
	Free lift, without load backrest	h_2	120	120	120	120	120	1501	1601	1951	2201	1500	1630	1900	2050	1461	1561	1721	1911	2161	2411	1500	1600	1700	1900	2050	2250
	Free lift, with load backrest	h_2	120	120	120	120	120	886	986	1336	1586	925	1055	1325	1475	886	986	1146	1336	1586	1836	925	1025	1125	1325	1475	1675
9FBH25T	Lift height	h_{23}	3045	3345	3745	4045	4545	3045	3345	3745	4045	3045	3345	3745	4045	4345	4735	5045	5545	6045	6545	4395	4745	5045	5545	6045	6545
	Lift	h_3	3000	3300	3700	4000	4500	3000	3300	3700	4000	3000	3300	3700	4000	4300	4690	5000	5500	6000	6500	4350	4700	5000	5500	6000	6500
	Height, mast lowered	h_1	2205	2355	2555	2755	3055	2135	2255	2585	2835	2205	2355	2550	2755	2135	2235	2395	2585	2835	3085	2205	2305	2405	2555	2755	2955
	Height, mast extended ¹⁾	h_4	3650	3950	4350	4715	5265	3730	4030	4430	4730	3655	3955	4355	4655	4930	5320	5630	6130	6630	7130	5000	5350	5650	6150	6650	7150
	Height, mast extended ²⁾	h_4	4215	4515	4915	5215	5715	4295	4595	4995	5295	4220	4520	4920	5220	5495	5885	6195	6695	7195	7695	5565	5915	6215	6715	7215	7715
	Free lift, without load backrest	h_2	125	125	125	125	125	1405	1525	1855	2105	1565	1715	1915	2115	1505	1605	1765	1955	2205	2455	1555	1655	1755	1905	2105	2305
	Free lift, with load backrest	h_2	125	125	125	125	125	885	1005	1335	1585	1030	1180	1380	1580	985	1085	1245	1435	1685	1935	1035	1135	1235	1385	1585	1785

1) Without load backrest.

2) With load backrest (optional); Height of load backrest is 1220 mm.

Pneumatic shaped cushion tyre			V					FV				FW				FSV					FSW						
9FBMK20T	Tilt range, forward	deg	4,25	4,25	4,25	4,25	4,25	4,25	4,25	4,25	4,25	4,25	4,25	4,25	4,25	4,25	4,25	4,25	4,25	4,25	4,25	4,25	4,25	4,25	4,25	4,25	4,25
	Tilt range, backward ¹⁾	deg	8	8	8	8	6	8	8	8	8	8	8	8	8	6	6	6	6	6	6	6	6	6	6	6	6
	Load capacity at 500 mm LC	kg	2000	2000	2000	2000	2000	2000	2000	2000	2000	2000	2000	2000	2000	2000	2000	2000	1950	1950	1850	2000	2000	2000	1950	1950	1850
9FBMK25T	Tilt range, forward	deg	4,25	4,25	4,25	4,25	4,25	4,25	4,25	4,25	4,25	4,25	4,25	4,25	4,25	4,25	4,25	4,25	4,25	4,25	4,25	4,25	4,25	4,25	4,25	4,25	4,25
	Tilt range, backward ¹⁾	deg	8	8	8	8	6	8	8	8	8	8	8	8	8	6	6	6	6	6	6	6	6	6	6	6	6
	Load capacity at 500 mm LC	kg	2500	2500	2500	2500	2500	2500	2500	2500	2500	2500	2500	2500	2500	2500	2450	2400	2300	2200	2000	2500	2450	2400	2300	2200	2000
9FBH25T	Tilt range, forward	deg	4,25	4,25	4,25	4,25	4,25	4,25	4,25	4,25	4,25	4,25	4,25	4,25	4,25	4,25	4,25	4,25	4,25	4,25	4,25	4,25	4,25	4,25	4,25	4,25	4,25
	Tilt range, backward ¹⁾	deg	8	8	8	8	6	8	8	8	8	8	8	8	8	6	6	6	6	6	6	6	6	6	6	6	6
	Load capacity at 600 mm LC	kg	2500	2500	2500	2500	2500	2500	2500	2500	2500	2500	2500	2500	2500	2500	2500	2500	2500	2450	2180	2500	2500	2500	2500	2500	2180
9FBH25T	Tilt range, forward	deg	4,25	4,25	4,25	4,25	4,25	4,25	4,25	4,25	4,25	4,25	4,25	4,25	4,25	4,25	4,25	4,25	4,25	4,25	4,25	4,25	4,25	4,25	4,25	4,25	4,25
	Tilt range, backward ¹⁾	deg	8	8	8	8	6	8	8	8	8	8	8	8	8	6	6	6	6	6	6	6	6	6	6	6	6
	Load capacity at 600 mm LC	kg	2500	2500	2500	2500	2500	2500	2500	2500	2500	2500	2500	2500	2500	2500	2500	2500	2450	2370	2300	2500	2500	2500	2450	2370	2300

1) Backward tilt range is 6deg on trucks with a cabin or front windshield

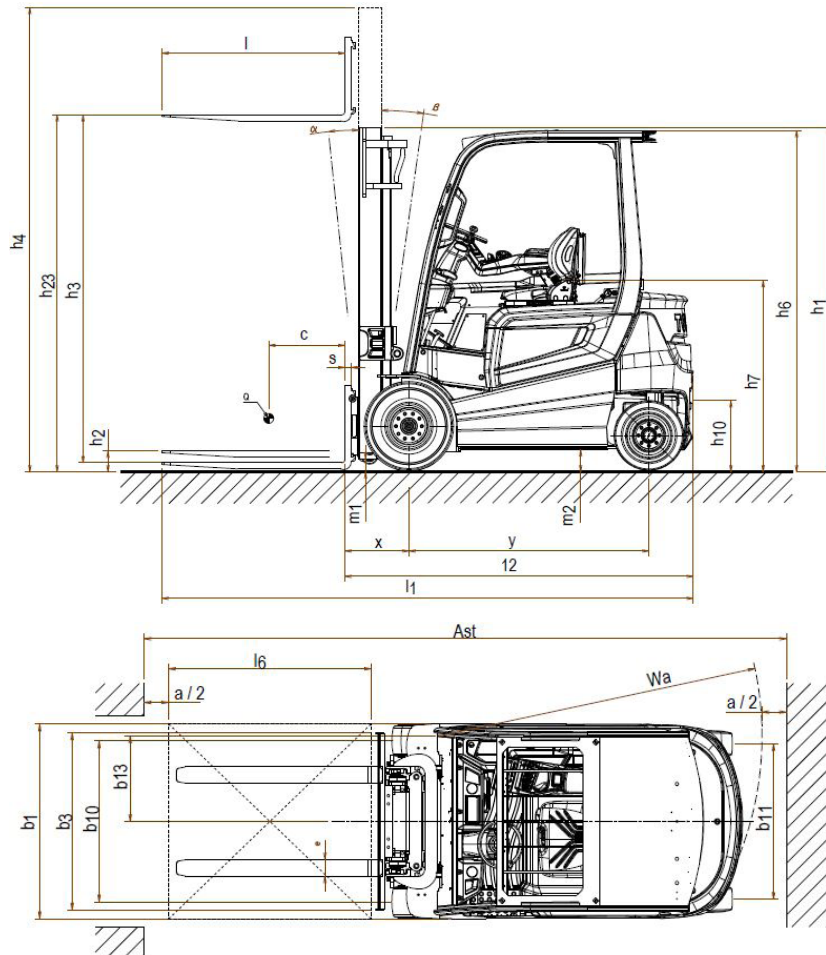

Standard equipment:

- Toyota SAS (System of Active Stability)
- Toyota AC power system
- Toyota ORS seat (Operator Restraint System)
- Toyota OPS (Operator presence system)
- Seat mounted hydraulic minilevers
- Wide visible mast (MFH:3300)
- Long forks ([Length: 1000 mm (9FBM(K)20-35T); 1200 mm (9FBH25-30T)
- Long forkbar (length: 1070 mm)
- 3 way valves
- Automatic parking brake
- Wet disc brakes
- Wide brake pedal
- Pneumatic shaped cushion tyres
- Full floating driver compartment
- Full hydraulic power steering
- Multifunction Display
- Memory tilt steering column
- Emergency stop button in armrest
- Assist grip
- Shockless landing lift

